

Gutter drains

The practical side of gutters.

Our practical gutter drains made of polymer are connected directly to the downpipe of the gutter and pass the rainwater through underground wastewater pipes and into the sewer, the stormwater collection tank or soakaways.



- 1 Downspouts 2 Drainage pipe 3 Extension section
- 4 Sludge basket 5 Drain cover 6 Odour trap

Removable sludge bucket

Our gutter drains are equipped with a sludge bucket as protection against blockages caused by solids such as leaves or branches. The trap basket can be easily accessed through the removable drain cover and is therefore easy to clean.

Odour trap

We also supply gutter drains with removable bell-shaped odour trap for frost-free depths from 545 mm to protect against unpleasant odours from the sewer.

Variable connection options

Optional extension sections can be used to attach additional lateral inlets to the gutter drains.

Gutter drain

Lateral or vertical outlet

Made in polymer

Rain inlet cover with protective pipe made of polymer.

With removable bell-shaped odour trap, two extension sections, sludge trap.

With wall securing device.

Drainage capacity 2.8 l/sec flow rate,

Note: For frost-free depth 545 mm

System 200



Outer diameter Ø (mm) Art. no.

Lateral outlet

Ø 110 67 970

Vertical outlet

Ø 110 67 960



Illustration shows Art. no. 67 970

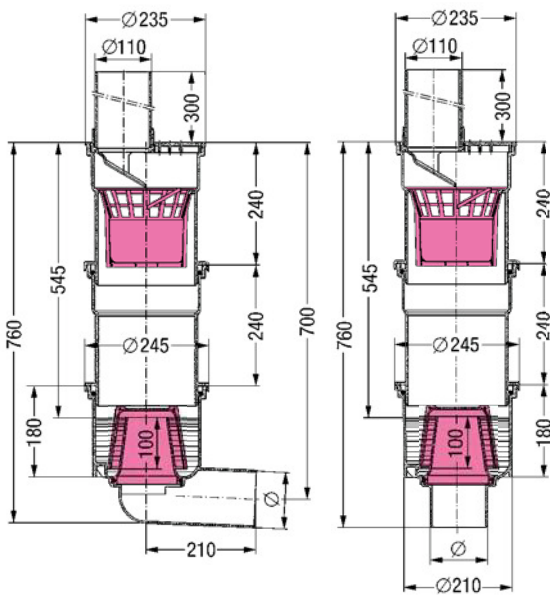

Illustration shows Art. no. 67 970

Illustration shows Art. no. 67 960

Gutter drain

Lateral or vertical outlet

Made in polymer

Rain inlet cover with protective pipe in synthetic material.

With sludge trap.

With/without wall securing device.

Drainage capacity 4.5 l/sec flow rate

System 200

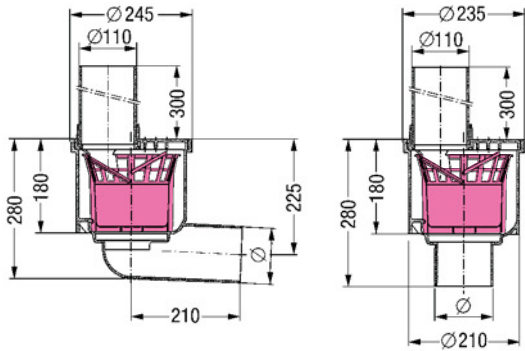

Illustration shows Art. no. 67 945

Illustration shows Art. no. 67 940



Illustration shows Art. no. 67 945

Lateral outlet

Outer diameter Ø (mm) Art. no.

With wall securing device

Ø 110 **67 945**

Vertical outlet

Outer diameter Ø (mm) Art. no.

With wall securing device

Ø 110 **67 940**

Without wall securing device

Ø 110 **67 997**

Modular system 200

System 200

Gutter drains

Upper section



in polymer

Cover: Cover plate Ø 218 mm class A 15 / L 15 (1.5 to.), sealed with respect to surface water

Art. no. **67 775**



in polymer

Cover: Rain inlet cover Ø 218 mm with protective pipe Ø 110

Ø 110 Art. no. **67 750**



in polymer

Cover: Rain inlet slotted cover Ø 218 mm, for additional surface drainage with protective pipe Ø 110

Ø 110 Art. no. **67 700**

Accessories



Extension section

Material: Polymer
Installation height: 240 mm without lateral inlet Art. no. **67 500**



Extension section

Material: Polymer
Installation height: 240 mm with lateral inlet Art. no. **67 600**



Sludge basket

Material: PE-HD
Art. no. **67 300**



Lip seal

Art. no. **27 140**



Lip seal

Non-slip mounting
Art. no. **27 141**



Bell-shaped odour trap insert

Material: PP, removable
sealing water height:
H = 70 mm (Art. no. **27 170**)
H = 100 mm (Art. no. **27 171**)

H 70 mm Art. no. **27 170**
H 100 mm Art. no. **27 171**

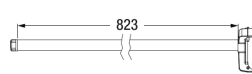

Lifting mechanism

For removing odour trap in case of deeper installation.
Compatibility: Art. no. **27 171, 67 960, 67 970**
Art. no. **850 144**



Wall securing device

Art. no. **67 800**

Drain body in polymer

without odour trap

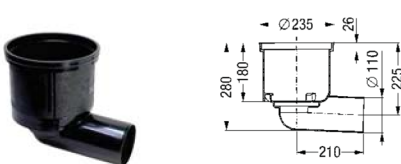

Lateral outlet 2.5°

Drainage capacity: 4.5 l/sec flow rate

Ø 110 Art. no. **67 000**

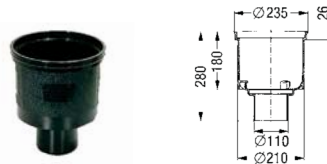

Vertical outlet

Drainage capacity: 4.5 l/sec flow rate

Ø 110 Art. no. **67 040**